

## BYV Series Butterfly Valves

2" TO 12" PVC BODY WITH PVC OR GFPP DISC

### KEY FEATURES & BENEFITS

- One Piece Injection Molded PVC Body
- PVC or GFPP Disc Materials
- Viton®, EPDM and Nitrile Seat Materials
- NSF / ANSI 61-G Listed
- Hand Lever with 19 Lockable Stop Positions & 360° Interlocking Splines
- External Disc Position and Flow Indication
- Hydro-dynamic Centric Disc for Increased Flow Performance
- Over-Sized Liner Face Maximizes Surface Contact with Flanges
- 1-Piece 316 Stainless Steel Stem with Threaded Retaining Gland
- Stem Bearing and Seal Retainer for Absolute Stem Position and Sealing
- ISO 5211 Top Flange and Stem Drive
- All Sizes Meet ANSI B16.10 / ISO 5752 Narrow Face-to-Face Dimensions
- Pressure Rated at 150 PSI / 10 Bar in All Sizes @ 70°F Non-Shock

### OPTIONS

- Over-Molded or Field Mountable 316 Stainless Steel Lugs
- Gear Operators
- Complete Range of Pneumatic or Electric Actuators
- Stem Extensions
- 2" Square Operating Nut
- Chain Operator for Gear Box

### MATERIALS

- PVC Cell Class 12454 per ASTM D1784
- GFPP Cell Class 85580 per ASTM D4101
- Viton®, EPDM or Nitrile Liners



PVC/EPDM  
2" - 12"

## TECHNICAL INFORMATION

### EXPLODED VIEW

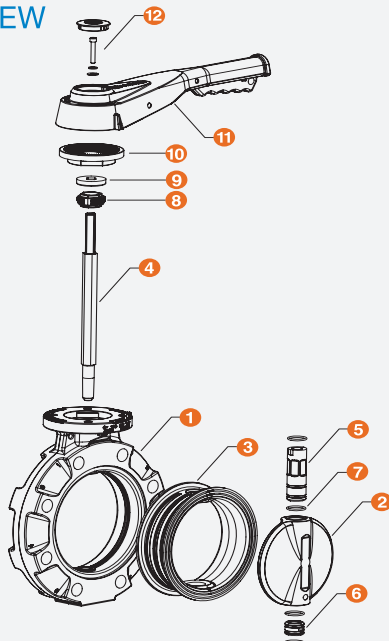

### SELECTION CHART

SIZE	BODY MATERIAL	DISC MATERIAL	LINER MATERIAL	PRESSURE RATING
2" - 12" (DN50 - DN300)	PVC	PVC or GFPP	Viton®, EPDM or Nitrile	150 PSI @ 70°F Non-Shock

[Click Here  
For Your Free Quote](#)

# BYV Series Butterfly Valves

2" TO 12" (DN50-DN300) PVC BODY WITH PVC OR GFPP DISC

## TECHNICAL INFORMATION, CONTINUED

### PARTS LIST / 2D DRAWINGS

1. Body
2. Disc
3. Liner
4. Stem
5. Upper Stem Bearings
6. Seal Retainer
7. O-Rings (4)
8. Threaded Retaining Gland
9. Weather Seal
10. Splined Throttle Plate (Ultem®)
11. Hand Lever Assembly
12. Bezel, Washers, Socket Head Cap Screw

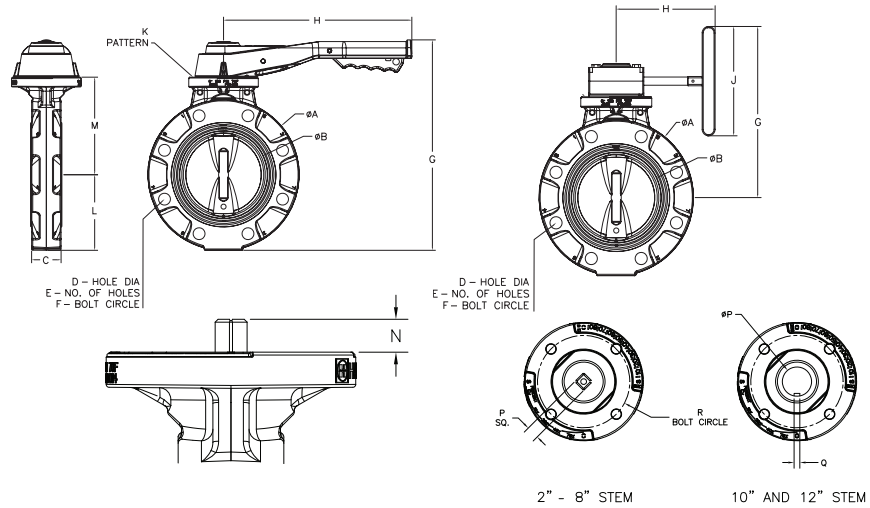

### DIMENSIONS – INCHES / MILLIMETERS

SIZE	A	B	C (1)	D, ANSI (2)	E	F, ANSI (2)	G	H	J	K (4) ISO 5211	L	M	N	P	Q, 10" & 12", SQUARE KEY	R	WEIGHT w LEVER lbs / Kg	WEIGHT w GEAR lbs / Kg		
in / DN	in / mm	in / mm	in / mm	in / mm	in / mm	in / mm	in / mm	in / mm	in / mm	in / mm	in / mm	in / mm	in / mm	in / mm	in / mm	in / mm	lbs / Kg	lbs / Kg		
2 / 50	6.12 / 155	2.03 / 52	1.69 / 43	0.75 / 19	4 / 4	4.75 / 121	7.53 / 191	6.25 / 159	4.75 / 121	10.5 / 267	5 / 125	F07-D11	3.17 / 81	3.97 / 101	0.51 / 13	0.430-0.433 / 10.92-11	-	2.76 / 70	4.0 / 1.8	5.8 / 2.6
2.5 / 65	7.25 / 184	2.50 / 64	1.81 / 46	0.75 / 19	4 / 4	5.50 / 140	7.96 / 202	6.67 / 169	4.75 / 121	10.5 / 267	5 / 125	F07-D11	3.63 / 92	4.40 / 112	0.51 / 13	0.430-0.433 / 10.92-11	-	2.76 / 70	4.9 / 2.2	6.7 / 3.0
3 / 80	7.75 / 197	3.25 / 83	1.81 / 46	0.75 / 19	4 / 8	6.00 / 152	8.31 / 211	7.00 / 178	4.75 / 121	10.5 / 267	5 / 125	F07-D11	3.88 / 99	4.75 / 121	0.51 / 13	0.430-0.433 / 10.92-11	-	2.76 / 70	5.2 / 2.4	7.0 / 3.2
4 / 100	9.13 / 232	4.12 / 105	2.06 / 52	0.75 / 19	8 / 8	7.50 / 191	9.29 / 236	8.00 / 203	7.28 / 185	12.00 / 305	5 / 125	F07-D14	4.57 / 116	5.69 / 145	0.68 / 17	0.548-0.551 / 13.92-14	-	2.76 / 70	7.7 / 3.5	11.1 / 5
6 / 150	11.25 / 286	5.98 / 152	2.19 / 56	0.88 / 22	8 / 8	9.50 / 241	12.35 / 314	10.00 / 254	7.75 / 197	14.00 / 356	8 / 200	F10-D14	5.63 / 143	7.25 / 184	0.68 / 17	0.548-0.551 / 13.92-14	-	4.02 / 102	12.7 / 5.8	16.2 / 7.4
8 / 200	13.75 / 349	7.75 / 197	2.38 / 60	0.88 / 22	8 / 8	11.75 / 298	13.48 / 342	11.18 / 284	7.75 / 197	16.00 / 406	8 / 200	F10-D17	6.88 / 175	8.38 / 213	0.77 / 20	0.666-0.669 / 16.92-17	-	4.02 / 102	18.5 / 8.4	21.9 / 10.0
10 / 250	16.13 / 410	9.63 / 245	2.69 / 68	1.00 / 25	12 / 12	14.25 / 362	16.37 / 416	N/A	9.00 / 229	N/A	10 / 250	F12-V28	8.06 / 205	10.88 / 276	2.24 / 57	1.102 DIA. / 28 DIA.	0.25 / 6.35	4.92 / 125	N/A	34.2 / 15.5
12 / 300	19.13 / 486	11.37 / 289	3.06 / 78	1.00 / 25	12 / 12	17.00 / 432	17.87 / 454	N/A	9.00 / 229	N/A	10 / 250	F12-V36	9.56 / 243	12.38 / 314	2.24 / 57	1.417 DIA. / 36 DIA.	0.25 / 6.35	4.92 / 125	N/A	50.4 / 22.9

- 1) Dimension per ASME B16.10 Class 150, Steel, Narrow  
 2) ANSI dimension per ASME B16.5, Class 150  
 3) Dimension per DIN 2501, PN10  
 4) ISO 5211 Flange and Drive  
 5) All weights are for non-lugged versions

### Cv VALUES

SIZE in / DN	DISC ANGLE					FULL OPEN POSITION
	15°	30°	45°	60°	75°	
2 / 50	0.2	15	37	65	88	92
2-1/2 / 65	1.1	24	45	80	145	165
3 / 80	3.1	28	36	83	182	250
4 / 100	20	58	84	183	390	470
6 / 150	30	105	200	458	1000	1510
8 / 200	125	203	375	770	1650	2820
10 / 250	123	289	644	1396	3003	4723
12 / 300	154	435	1011	2189	4586	6400

### PRESSURE LOSS CALCULATION FORMULA

$$\Delta P = \left[ \frac{Q}{C_v} \right]^2$$

$\Delta P$  = Pressure Drop  
 $Q$  = Flow in GPM  
 $C_v$  = Flow Coefficient

### OPERATING TEMPERATURE / PRESSURE

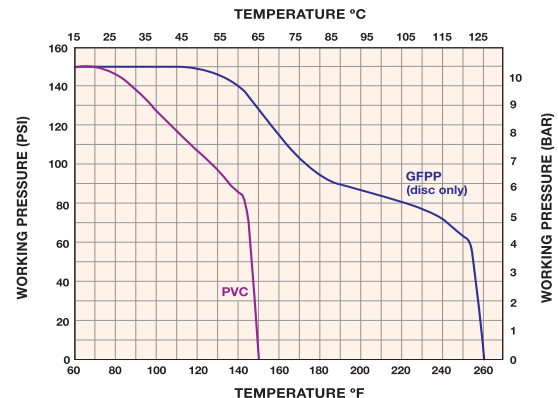

Hayward is a registered trademark of Hayward Industries, Inc.  
 © 2014 Hayward Industries, Inc.